

//retail display solutions

design

distinction

modular

cutting edge solutions for retailers and brands



retail display solutions

retail display

The range of display solutions have been designed using a modular approach and can be adapted to suit most retail display applications.

//a complete retail display solution



The range of retail display products provide high quality, cutting edge solutions for retailers, brands and designers. The versatility of the Modular System has been used to create a product range including: counters, showcases, display stands and stand alone retail merchandising units.

//retail display

The system can also be customised to create light walls, partitions, cladding and bespoke displays and is the retail display system of choice both internationally and in the UK.



retail display solutions

- design
- distinction
- modular

introduction

Counter Showcases Secure counter range available in standard and bespoke configurations to suit specific needs.

Tower Showcases Can be used free standing or linked in a modular layout and enhanced with stunning lighting and finishes.

Gondolas Made from 8mm tempered safety glass, offering contemporary open displays with no barriers to purchase.

//choice

All display products are designed and manufactured to the highest specifications. The system offers unbeatable quality and flexibility and presents the opportunity to create the retail display layout and environment you desire.



design and detail	p4/5	tower showcases	p10/11
counter showcases	p4/5	blade showcases	p12/13
counter showcases	p6-9	gondolas	p14/15

retail merchandising units	p16/17	wall cabinets	p18
display stands	p19		



Display Stands Shelving units, illuminated walls, product display stands. The design team can deliver solutions for all.

Retail Merchandising Units Allow brands and retailers self-contained secure merchandising opportunities in areas offering maximum impact.

The wide range of feature profiles and accessories, create individual and inspirational interior displays.

//a complete retail display solution



By combining the range of retail display profiles with material finishes including real wood veneers, digital graphics, tempered glass and lighting, simply stunning designs are created. Be it secure or open stands, offers design solutions that your competitors will envy.

//design

anodised aluminium profiles are at the heart of all our retail display products. All showcases are factory built, tested and ready to use.

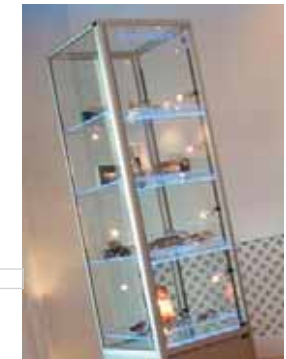

eye catching products

By imaginatively combining profiles from the range and blending them with other materials and finishes, unique displays can be created to give your interior that premium look.

retail display solutions

counters

gondolas

showcases

design

Security High quality locks for both hinged and sliding, glass and cupboard doors.

Finishes Rounded or square, slim line or chunky, chrome or matte. All corner details are precision die cast and made to exacting tolerances.

Doors Tempered safety glass doors with crystal polished edges can be supplied hinged or sliding.

//detail

At times our obsession with detail drives us crazy. The resultant effect being better engineered design solutions with attention to detail that makes our range sell more products and last longer, whilst offering optimum security and meeting all appropriate safety standards.



Castors All showcases are supplied with twin wheel swivel castors as standard. Inset shows optional tilt glide feet.

Lighting Halogen spotlights offer adjustable and intense product illumination for maximum impact.

LED Edge Lighting LED edge lighting combined with product illumination ensures that your products will not be missed.

attention to detail

- secure merchandising
- fine finishes
- adjustable shelving
- high quality lighting
- modular design
- tempered safety glass

design and detail

Security is paramount in all counters.

Our standard range has locking glass sliding doors to both display and storage areas.



The counter range is set apart by its simplicity. A versatile range of counters and till points allows you to create stylish and effective retail environments to meet every conceivable need.

//counter showcases

counter showcases are equally effective when used freestanding or linked together to create islands and flush fit counter display solutions.



retail display solutions

counter showcases

//unique contemporary design

The range consists of all glass, glass with storage facility and all storage counters. Corner units, till points and counter tops provide infinite linked solutions to fit any space.

//created to complement any layout

Combining the various elements of the Unibox counter range gives retailers and designers the option of creating island displays or full store interiors for maximum merchandising effect.

//create

There is a wide range of standard sizes that can be complemented with our bespoke unit design service.

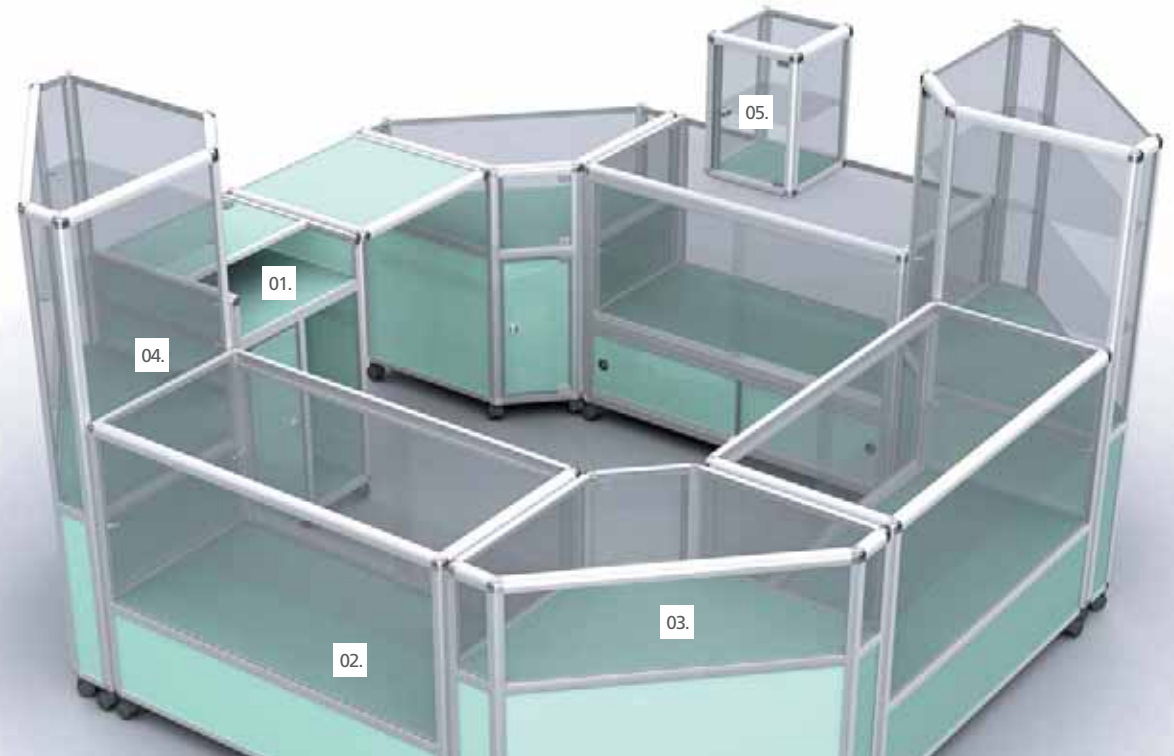

counter showcases

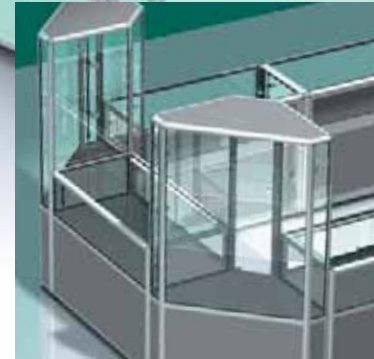
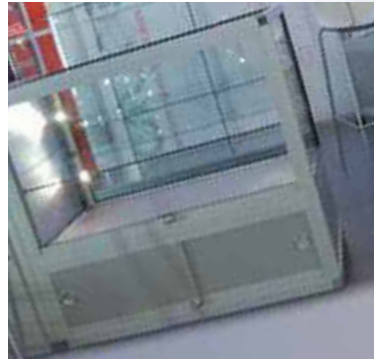

counter showcases

01. Till Points

Designed to accommodate PC storage, cable management, cash desks and monitors.

02. Counters

Available in various dimensions with combinations of display and storage to suit most requirements.

03. Corner Units

Designed to be combined with counters for island displays.

04. Corner Towers

Combined with counters corner towers offer maximum merchandising potential.

05. Counter Tops

These cabinets offer POP merchandising potential, can be branded and co-ordinated with counter configurations.

The standard cabinet range is available in satin silver finish, with other finishes available on request including chrome, polished gold, wood grain and stainless steel effects.

full display counter

ub01 w1000mm d600mm h900mm

ub02 w1250mm d600mm h900mm

ub03 w1500mm d600mm h900mm



two thirds display counter

ub04 w1000mm d600mm h900mm

ub05 w1250mm d600mm h900mm

ub06 w1500mm d600mm h900mm



one third display counter

ub07 w1000mm d600mm h900mm

ub08 w1250mm d600mm h900mm

ub09 w1500mm d600mm h900mm



solid counter

ub44 w1000mm d600mm h900mm

ub45 w1250mm d600mm h900mm

ub46 w1500mm d600mm h900mm



full display corner counter

ub22 w810mm d810mm h900mm



two thirds display corner counter

ub23 w810mm d810mm h900mm



one third display corner counter

ub24 w810mm d810mm h900mm



solid corner counter

ub47 w810mm d810mm h900mm

retail display solutions

counter

corner counter

Our fastidious attention to detail makes our products enhance any retail environment, whether used as a free standing display or whole interior solution.

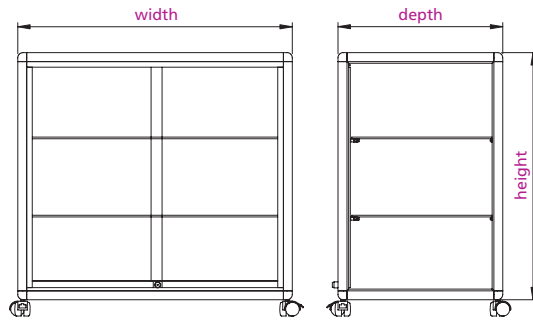

counter top showcase

ub28 w 350mm d 350mm h 350mm

counter shelf unit

ub32 w 600mm d 600mm h 900mm



corner tower showcase w 810mm d 810mm h1932mm

ub37 to match full display counter

ub38 to match two thirds display counter

ub39 to match one third display counter



counter top showcase

ub27 w 350mm d 350mm h 700mm



counter till point

ub30 w 600mm d 600mm h 900mm



counter showcases

corner showcase

counter till point

counter shelf unit

counter top showcase

counter showcases

All cabinets are manufactured in the UK using tempered safety glass (BS6206 class A).



Tower showcases are the most popular choice for both retailers and brands. They offer maximum visual impact, securely displaying all manner of high value or fragile goods and can be merchandised to consistently promote sales. Many leading international brands choose towers for their instore POP displays.

//tower showcases

towers offer visually appealing, secure display solutions that can be configured to offer brand identity or co-ordinated with your interior finishes.



//secure display solutions

Full height hinge door stops and sliding door anti lift out blocks are fitted as standard. Optional alarms are available for additional security.

retail display solutions

tower showcases

//leading innovations in retail

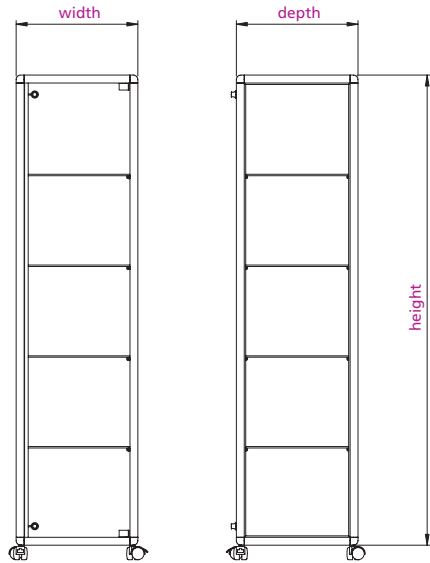

full display tower showcase			
ub10 standard		ub13 wide	
height	1932mm	height	1932mm
depth	500mm	depth	450mm
width	500mm	width	1000mm



full display tower showcase with header panel			
ub11 standard		ub14 wide	
height	1932mm	height	1932mm
depth	500mm	depth	450mm
width	500mm	width	1000mm



three quarter display tower showcase			
ub25 standard		ub26 wide	
height	1932mm	height	1932mm
depth	500mm	depth	450mm
width	500mm	width	1000mm



three quarter display tower showcase with header panel			
ub12 standard		ub15 wide	
height	1932mm	height	1932mm
depth	500mm	depth	450mm
width	500mm	width	1000mm



tower showcases

tower showcases

Showcases with header panels include 3 piece 35 watt halogen 240 volt downlight set as standard.

Cupboard height on three quarter display showcases is 430mm.

Inspired by a visit to Ferrari in Maranello, Italy, the Blade design encompasses details from the F1 cars on display and the beautifully designed store interior.



//blade showcases

The blade showcase range was conceived as retail furniture that can be combined with graphic displays to create stunning and highly individual retail display units. The aerofoil shaped corner profiles make a bold statement and are particularly suitable for product promotions.

Designers have selected the range to promote fashion items, electrical goods, cameras, perfumes and cosmetics.



retail display solutions

blade showcases

//a truly contemporary look

Use a variety of colours and materials to feature alongside the blade profile for that modern contemporary look.

//contemporary solutions

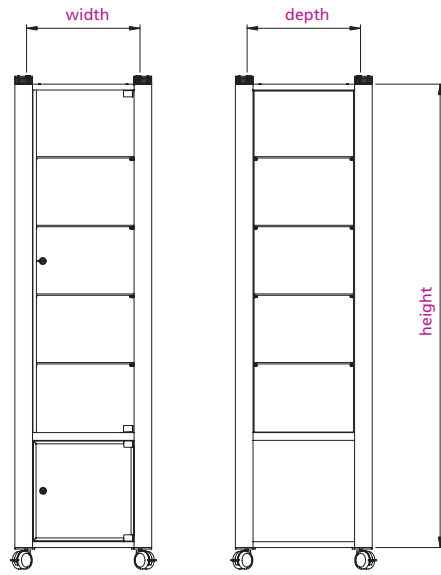

Designer castors complete the stylish, chic design.

blade full display tower showcase			
ub10 blade		ub11 blade with header panel & 3 piece downlighter set	
height	1932mm	height	1932mm
depth	500mm	depth	500mm
width	500mm	width	500mm

blade three quarter display tower showcase			
ub25 blade		ub12 blade with header panel & 3 piece downlighter set	
height	1932mm	height	1932mm
depth	500mm	depth	500mm
width	500mm	width	500mm

blade full display tower showcase wide			
ub13 blade		ub14 blade with header panel & 3 piece downlighter set	
height	1932mm	height	1932mm
depth	450mm	depth	450mm
width	1000mm	width	1000mm

blade three quarter display tower showcase wide			
ub26 blade		ub15 blade with header panel & 3 piece downlighter set	
height	1932mm	height	1932mm
depth	450mm	depth	450mm
width	1000mm	width	1000mm



Blade three quarter display tower

blade showcases

blade showcases

A wide range of sizes to suit a variety of needs that are available to order ex-stock.



The gondola range is ideal for use in retail displays where the product is the star and there are no barriers to purchase. They are particularly suitable for the display of giftware, glassware, china and electrical goods creating an impact in any retail environment.

//gondolas

The glass gondola range has been designed to complement the showcase range.



retail display solutions

gondolas

//create an impact

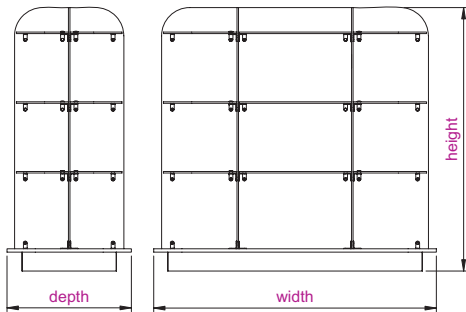

gondola 01	
ug01	
height	1400mm
depth	660mm
width	1500mm

gondola 02	
ug02	
height	1400mm
depth	660mm
width	1120mm

gondola 03	
ug03	
height	1400mm
depth	660mm
width	730mm

gondola 04	
ug04	
height	1400mm
depth	660mm
width	2110mm

gondola 05	
ug05	
height	1400mm
depth	660mm
width	1900mm

gondola 06	
ug06	
height	1400mm
depth	660mm
width	1510mm

gondola 07	
ug07	
height	1400mm
depth	660mm
width	1130mm

Constructed from 8mm CNC machined, tempered safety glass and joined by chrome plated connector brackets, the gondolas sit on sturdy 18mm thick wooden bases that are offered in a range of finishes that match those of showcases.

High quality chrome fixings for stylish glass to glass connections.

gondolas

gondolas



If your perception of a retail merchandising unit is a brightly painted horse and cart (minus the horse!), awkwardly sitting in a shopping mall walkway, crammed with goods, think again.



RMUs well and truly break the mould. Manufactured in the UK with the structural elements of the Modular System, they are more like miniature modernist buildings than market stall carts.

Extensive use of aluminium profiles, tempered safety glass, CNC fabricated steelwork and electrically operated security shutters ensure that Unibox RMUs can be styled to meet retailer and brand aspirations.

//retail merchandising

Our standard and bespoke solutions will attract maximum sales impact in areas of heavy foot fall. They offer mall and other property managers the opportunity to create extra retail floor space and premium income.



RMUs are fully factory built in modules and assembled at site in record time without the need for civil work.

retail display solutions

RMUs

//individually designed to meet your needs

If you want to maximise sales in public spaces, be it fashion ware, consumer electronics, jewellery, flowers, cameras or brand promotions... why not explore the possibilities with the design team.

units



retail merchandising units



retail merchandising units

All power and data transfer requirements can be accommodated and are designed and inspected by NICEIC approved electrical engineers. Firetrace® automatic fire detection and extinguisher system, configured and fitted by our own certified engineers, complies with legislation and protects your investment.

Design details and construction quality match those of architect designed, modern buildings. RMUs are designed to perform...for years.

For an individual look, showcases can be powder coated to match corporate colours and branding.



All our wall mounted cabinets are supplied with heavy duty keyhole brackets enabling them to be securely yet discreetly fixed to the wall. Made to the same exacting standards as our counters and towers, wall mounted cabinets can be supplied both with and without lighting and can also be supplied with branded or illuminated header panels.

//wall cabinets

Wall mount cabinets are perfect for mounting at eye level and take up no floor space making them ideal for smaller spaces.



retail display solutions

wall cabinets

wall cabinet showcases

ub20	
height	1000mm
depth	250mm
width	1000mm



ub21	
height	1000mm
depth	250mm
width	1000mm



ub21 features 3 piece 35watt halogen 240 volt downlight set.

The system gives you the freedom to create a display solution that is unique, stylish and eye-catching. Be inspired



The Modular System has been used to create a vast array of bespoke display stands. Its modular nature allows high quality bespoke display stands to be designed, developed, prototyped, brought to production and roll out in record time.

//display stands

What type of stands have been made? Football pitch advertising hoardings, motorcycle helmet displays, Peugeot showroom graphics, Vodafone interactive units, football display stands for Mitre, and more... many more.



display stands



display stands

Talk to our design team about how to adapt for your next project.

United Aluminium

//retail display solutions



John Ellis Shop Equipment Limited

TEL: 01223 892283 FAX: 01223 891572
johnellis@shopequip.co.uk

www.shopequip.co.uk

retail display solutions